

645 DL

6" Drainable Louver



Application:

High flow-thru design with drainable head with integrated blade gutter allowing water to cascade between blades providing minimum water penetration. Hidden mullion allows for continuous blade appearance.
 Aluminum construction for high resistance to corrosion.

Material:

6063-T5 .081" aluminum frame
 6063-T5 .081" aluminum blades

Sizes:

Minimum size: 12" x 12"
 Maximum section: 60" x 96"
 OptL. blade seals: 48" x 96"
 Sections can be field assembled to construct larger sizes.

Features:

53% Free Area @ 48" X 48"
 back blade full open
 Solid frame construction
 All aluminum construction
 Outstanding durability
 Low maintenance
 Easily removable screens

Options:

Pneumatic or electric actuators
 High Wind load bracing
 Bird Screen
 Insect screen

Finishes:

Mill Finish
 Clear Anodize
 Prime Coat
 Baked Enamel Finish
 Kynar
 Color Anodizing

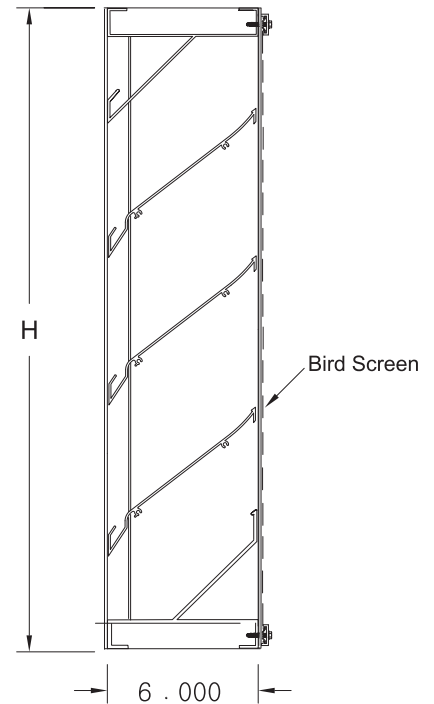
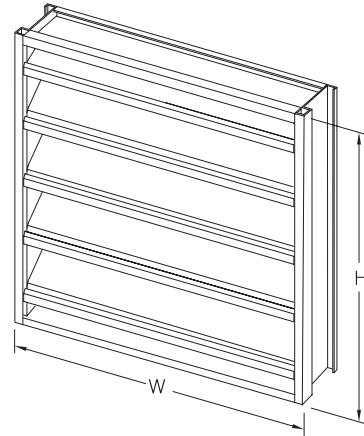

REPRESENTATIVE:	CONTRACTOR:
ARCHITECTURAL	LOCATION
ENGINEER	PROJECT
	DATE